

MEDIUM VOLTAGE IGCT CONVERTER

**Address**

Via Archimede 18
Sesto San Giovanni (MI) 20099
Italy

Phone

T: +39 02.26.22.40.54
F: + 39 02.24.06.945

Email / Web

commerciale@secompower.it
info@secompower.it
www.secompower.it

About Us

FOUNDED IN 1975, SECOM IS A LEADING COMPANY FOR THE DISTRIBUTION AND PRODUCTION OF COMPONENTS AND DEVICES FOR POWER ELECTRONICS

SECOM continuously carries out new research and technical proposal in conjunction with important clients, providing technical support to meet their specific needs.

Production excellence and efficient organization allow SECOM to commit itself to providing to the market with timely and professional service in numerous sectors of static energy conversion. Flexibility and short delivery time have become pillars to SECOM's company policy.

WHO WE ARE



Over the years the company has become an important designer and manufacturer of power electronic devices for industrial automation manufacturing technologies

WHAT WE DO



SECOM studies and manufactures customized solutions on behalf of its customers.

CONTENTS

4	OVERVIEW
6	MECHANICAL DESCRIPTION
8	CABINET LAYOUT
10	TECHNICAL DATA

IGCT CONVERTER

OVERVIEW

SECOMDRIVE MV IGCT Inverter are high performance water cooled drives in three level Neutral Point Clamped (NPC) topology.

Power stage can also be used as Active Front End (-) regenerative converter.

SECOMDRIVE MV IGCT Inverter meet the following requirements:

- High dynamic performances
- High power rating at low frequencies
- Line power factor = almost 1.0 (AFE version)
- Four-quadrant operation (AFE version).

The line side and motor-side converters use IGBT modules in a range from 10 MVA to 13 MVA.

The IGCT power Stack is a complete 3-phase Inverter solution in a unique wheel stand module and each phase is on a single removable drawer.

The development of new power semiconductors such as 4,5 and 6 kV Insulated Gate Commutated Transistors (IGCT), the improved design and the diffusion of the 3 levels Inverters have led to an increase of the market share of PWM (Pulse Width Modulation) Medium Voltage Inverters.

These Inverters are becoming competitive respect to the traditional thyristors converters because of reduced line harmonics, a better power factor and the suppression of the power transformer.



IGCT CONVERTER

OVERVIEW

There are **four typologies** of phase module:

- 10 MVA
- 11 MVA
- 12 MVA
- 15 MVA

The maximum output voltage of a three Levels Neutral Point Clamped Voltage Source Inverter (3L NPC VSI) is limited to about 4.16 kV, using a 5.5 kV IGCT; to increase the output voltage the serial connection of the semiconductors is needed.

According to the controller parameters setting, and thanks to the modular design of the drive, the series SD.MT.V33.GCT Inverters can be also configured as AFE (Active Front End) and therefore can supply a DC bus bar feeding several Inverters and work as a regenerative unit.

The common DC bus enables energy savings when several Inverters and motors are connected: energy generated from a motor, or section of motors, during braking can be used by another one linked to the bus.

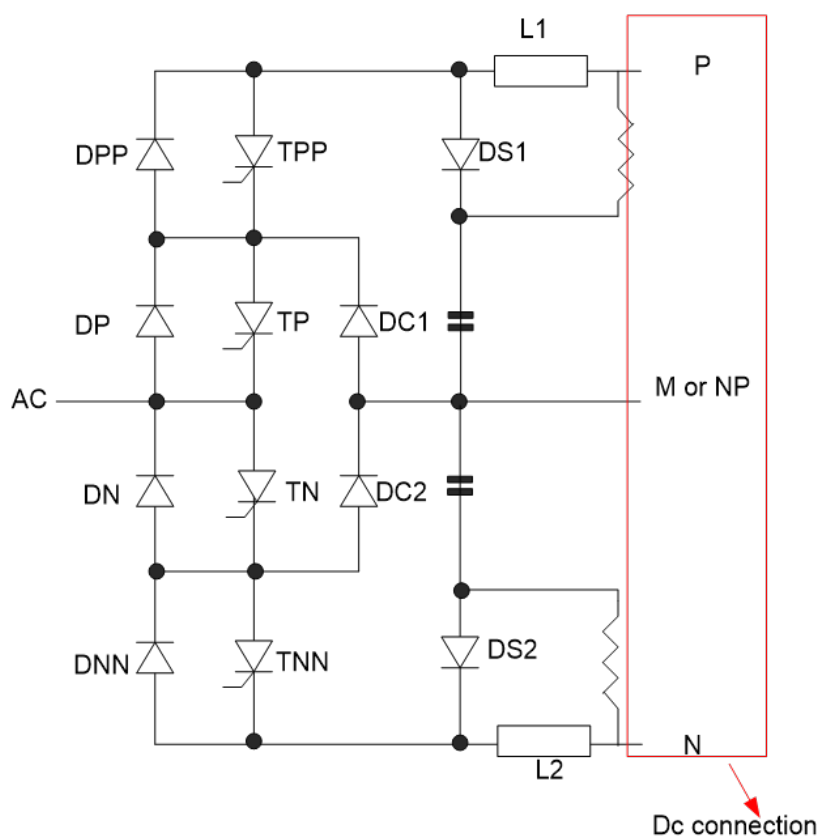

MECHANICAL DESCRIPTION

A single module corresponds to an electrical phase.

The figure below shows the assembly of the module called "phase module".

The mechanical design of the drive respect the component position as per schematic diagram (figure below), offering a symmetrical layout that reduce the maintenance and service times.

The module has been designed to be installed inside a cabinet, for this reason its protection degree is IP00.

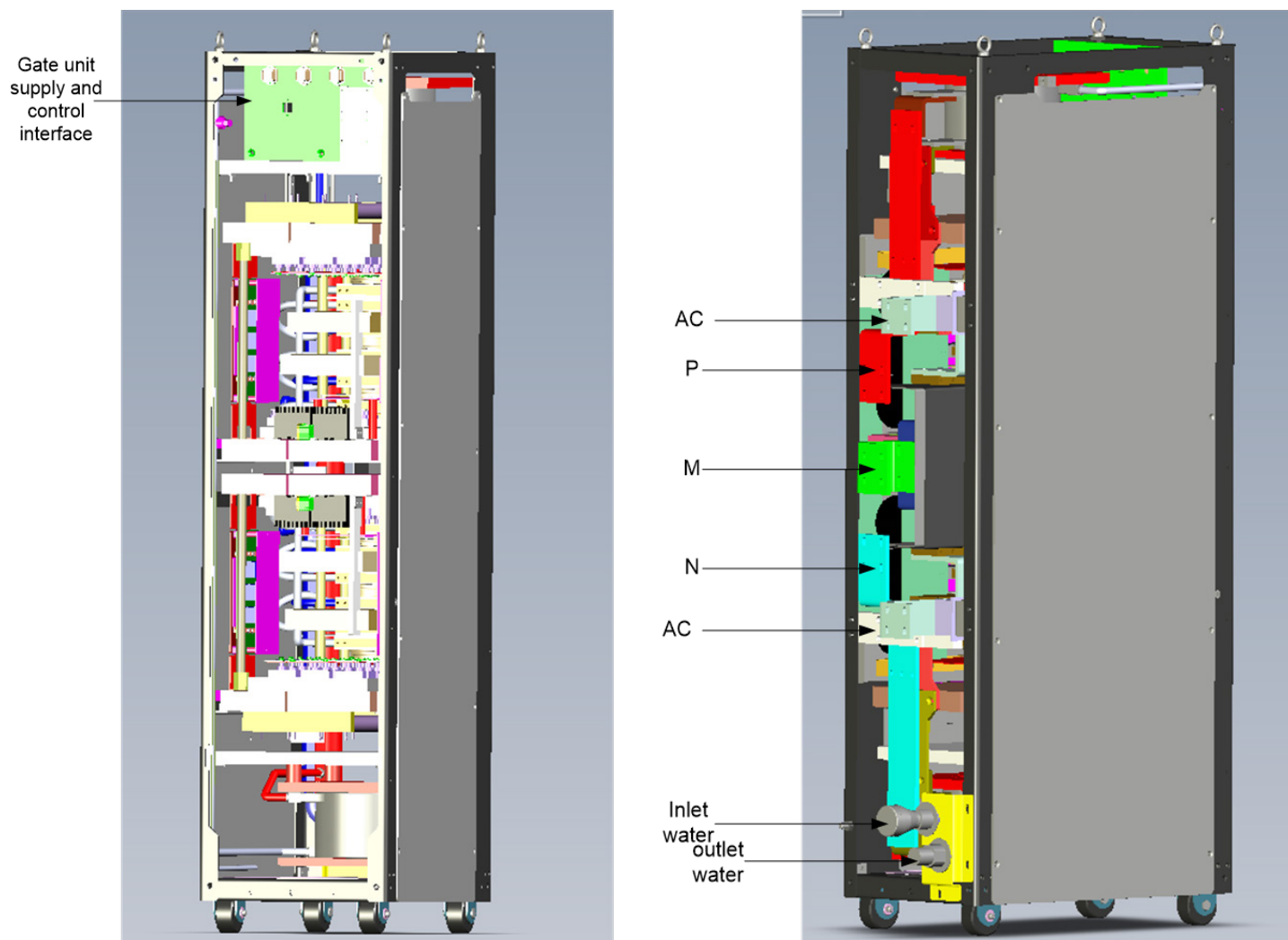

MECHANICAL DESCRIPTION

The module is provided with wheels in order to simplify the handling and installation inside a cabinet. Four eyebolts facilitate the lifting of the unit.

The frame has been realized in nonmagnetic material, like aluminium and stainless steel, and polyester resin GPO3, for its dielectric property.

The copper bars are located in the rear side of the module, while the input/output signals connectors are located in front position.

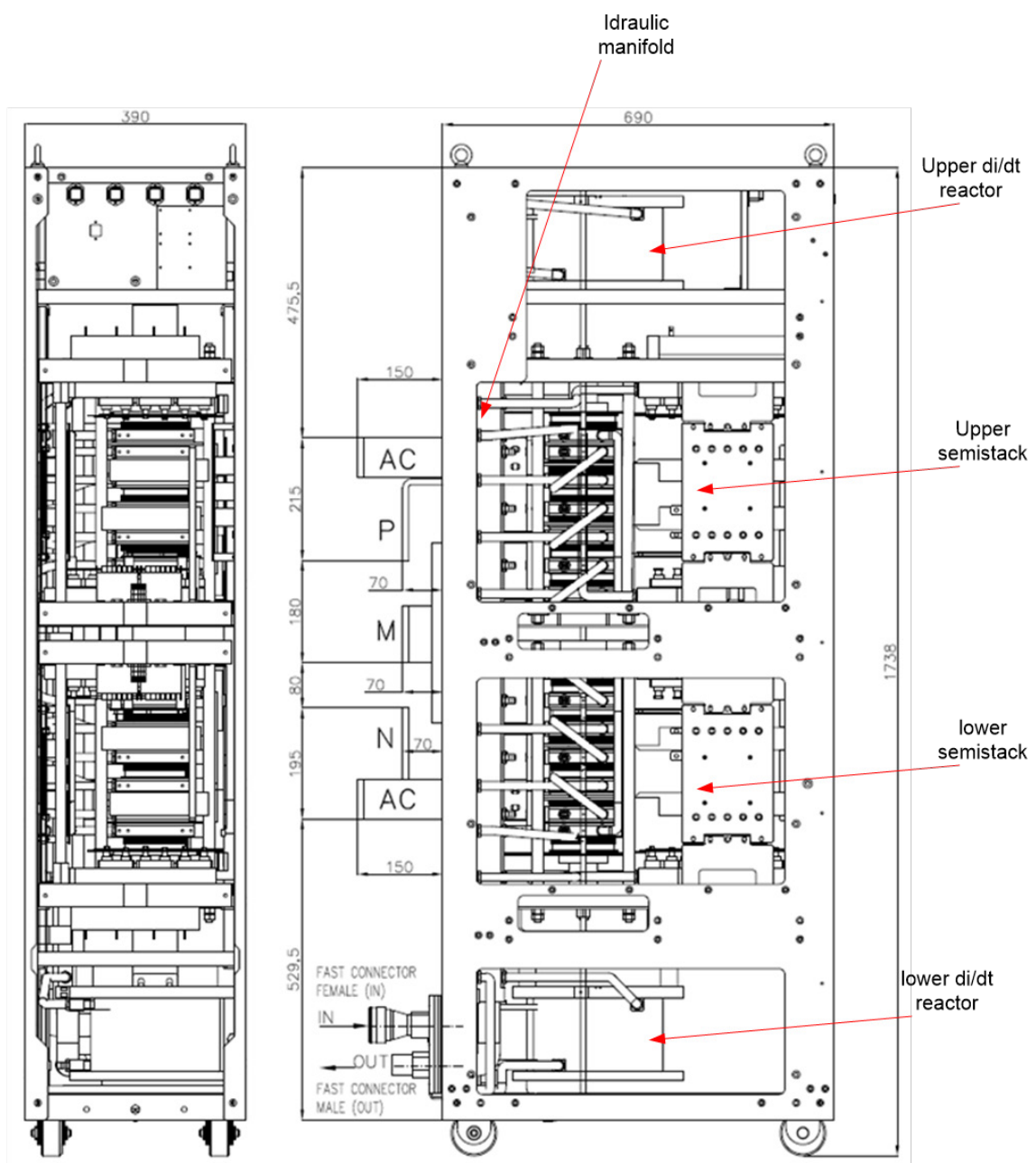

IGCT CONVERTER CABINET LAYOUT

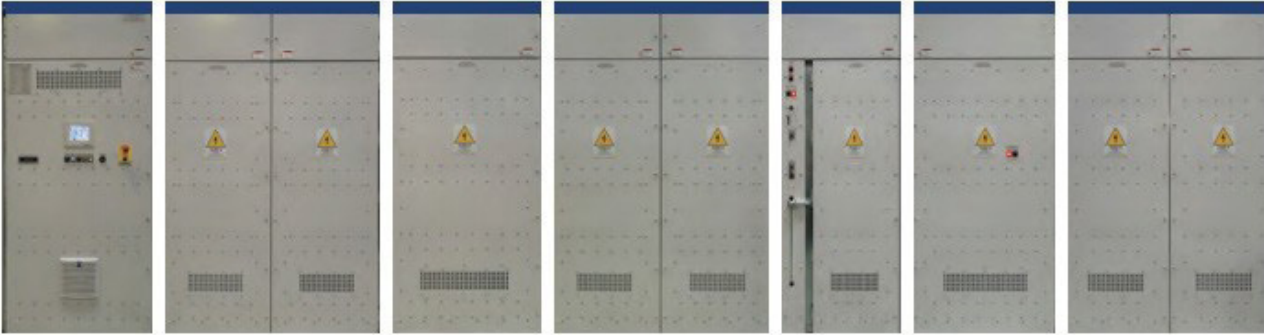
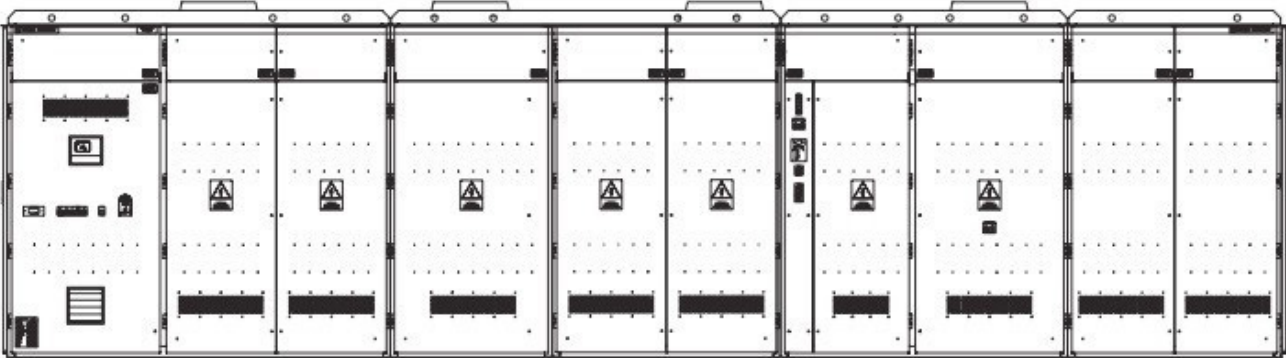

AFE TERMINAL UNIT	AFE UNIT	CAPACITOR UNIT	INVERTER UNIT	CROWBAR SECTION	INVERTER TERMINAL UNIT	COOLING WATER UNIT
-------------------	----------	----------------	---------------	-----------------	------------------------	--------------------

IGCT CONVERTER CABINET LAYOUT



TECHNICAL DATA

Environment conditions	
Altitude	1000 m above sea level
Climate	Temperate
Operating temperature (min./max.)	0 ÷ 40°C
Storage temperature	0 ÷ 40°C
Humidity	10 ÷ 90%
Copper (Cu)	< 0.1 mg/l
Undissolved particles	< 5 mg/l

Dimension and weight	
Height	1780 mm
Width	390 mm
Depth (with output bars)	840 mm
Total weight	280 kg

Electrical data for 10 MVA module	
Converter type	VSI (Voltage Source Inverter)
Cooling	Water
Nominal switching frequency	400 Hz
Overload current	1750 A
Base continuous current to apply max overload	1360 A
Continuous current	1400 A
Supply voltage (AFE)	3.3 kV
Output voltage (INV)	3.15 kV
Maximum semibus voltage	2800 V _{DC}
Efficiency	98%
Minimum switching time	80 µs
Dead time	40 µs
Water power losses	15 kW
Air power losses	< 1 kW

TECHNICAL DATA

Electrical data for 11 MVA module	
Converter type	VSI (Voltage Stiff Inverter)
Cooling	Water
Nominal switching frequency	300 Hz
Overload current	1890 A
Base continuous current to apply max overload	1450 A
Continuous current	1500 A
Supply voltage (AFE)	3.3 kV
Output voltage (INV)	3.15 kV
Maximum semibus voltage	2800 V _{DC}
Efficiency	98%
Minimum switching time	80 μs
Dead time	40 μs
Water power losses	18 kW
Air power losses	< 1 kW

Electrical data for 12 MVA module	
Converter type	VSI (Voltage Stiff Inverter)
Cooling	Water
Nominal switching frequency	300 Hz
Overload current	2050 A
Base continuous current to apply max overload	1580 A
Continuous current	1500 A
Supply voltage (AFE)	3.3 kV
Output voltage (INV)	3.15 kV
Maximum semibus voltage	2800 V _{DC}
Efficiency	98%
Minimum switching time	80 μs
Dead time	40 μs
Water power losses	20 kW
Air power losses	< 1 kW

TECHNICAL DATA

Electrical data for 15 MVA module		
Voltage	Vin AC (Vrms) (as AFE)	3300 ± 10%
	Maximum Total DC bus (V_{DC})	5600
	Semi stack (V_{DC})	2800
Nominal current rating	Base continuous current to apply maximum overload (Arms)	1900
	Maximum overload current (Arms)	2650 with $T_{min} = 100 \mu s$
	Overcurrent trip threshold (A_{pk}^2)	4100
Nominal switching frequency (Hz)	Mean or device switching frequency (Hz) Case 1 ³ /2 ⁴	210/235
Minimum Ton Time	μs	100
Dead time	μs	40
Switching frequency as AFE For 50 or 60 Hz line frequency	250 Hz (5x) Mot/reg	2620/2420
	300 Hz (5z) Mot/reg	2500/2200
	350 Hz (7x) Mot/reg	2200/2000
	420 Hz (7x) Mot/reg	1920/1800
Water power losses (kW)	25	
Air power losses (kW)	< 1 kW	

Via Archimede 18
Sesto San Giovanni (MI), 20099

CONTACT INFO

T: +39 02.26.22.40.54
Fx: +39 02.24.06.945

info@secompower.com
commerciale@secompower.com
www.secompower.it